

PRODUCT SPECIFICATION

Part No.:	BSFP-MM13102K	
Description:	155M SFP Transceiver,MMF 1310nm 2km	
Release Date	Rev.	Revision Change Description
2015/06/07	A0	New Release
2020/12/28	A1	Template Update

Features

- ✧ Up to 155Mbps data rate
- ✧ 1310nm FP Laser and PIN photo detector
- ✧ Duplex LC receptacle optical interface compliant
- ✧ Single +3.3V power supply
- ✧ Hot-pluggable
- ✧ Metal enclosure, for lower EMI
- ✧ International Class1 laser safety certified
- ✧ Operating temperature range:
- ✧ Commercial: 0°C~+70°C
- ✧ Industrial: -40°C~+85°C
- ✧ RoHS Compliant
- ✧ DDMI function available with internally calibrated mode
- ✧ Up to 2km transmission distance over Multi-Mode Fiber(MMF)

Application

- ✧ SDH STM-1, I-1
- ✧ Sonet OC-3,SR1
- ✧ Fast Ethernet
- ✧ Other Optical Links

Standard

- ✧ Compliant with SFF-8472
- ✧ Switched Backplane Applications
- ✧ Router/Server Interface

Specification

Absolute Maximum Ratings				
Parameter	Symbol	Min	Max	Unit
Storage temperature	TS	-40	85	°C
Power Supply Voltage	Vcc	-0.5	+4	V
Relative Humidity	RH	5	95	%
Signal Input Voltage		-0.3	Vcc+0.3	V
Receiver Damage Threshold		+5		dBm

Recommended Operating Conditions					
Parameter	Symbol	Min	Typical	Max	Unit
Operating Case Temperature (Commercial)	Tc	0		70	°C
Operating Case Temperature (Industrial)		-40		85	
Power Supply Voltage	Vcc	3.13	3.3	3.47	V
Ambient Humidity	HA	5		70	%
Supply Current	Icc			300	mA
Data Rate		-	155	-	Mbps
Fiber Length 9/125µm core SMF		-	2	-	km

Electrical Characteristics						
Parameter	Symbol	Min	Typical	Max	Unit	Notes
Total Supply Current	ICC			A(TX)	mA	A (TX) + B (RX) = 300mA
Transmitter Disable Input-High	VDISH	2		Vcc+0.3	mV	
Transmitter Disable Input-Low	VDISL	0		0.8	V	
Transmitter Fault Input-High	VDISL	2		Vcc+0.3	V	
Transmitter Fault Input-Low	VTxFH	0		0.8	V	
Total Supply Current				B(RX)	mA	A (TX) + B (RX) = 300mA
Loss of Signal (LOS)	Voh	2		Vcc+0.3	V	
	Vol	0		0.8	V	
Optical transmitter Characteristics						
Parameter	Symbol	Min	Typical	Max	Unit	Notes
Average Output Power	Pout	-15		-8	dBm	1
Operating Wavelength Range	λc	1270	1310	1360	nm	
Spectrum Bandwidth(RMS)	σ			4	nm	

Side Mode Suppression Ratio	SMSR	30				dB	
Extinction Ratio	ER	9				dB	2
Differential Line Input Impedance	RIN	90	100	110		Ohm	
Jitter P-P	t_j				0.1	UI	
Optical Tx Output disable	P_{dis}				-45	dBm	
Output Eye Diagram	Complies with IEEE802.3 z (class 1 laser safety)						
Optical receiver Characteristics							
Parameter		Symbol	Min	Typical	Max	Unit	Notes
Receiver Sensitivity		S			-24	dBm	4
Wavelength Range		λ_c	1270		1610	nm	
Receiver Reflectance					-12	dB	
Input Saturation Power (Overload)		P_{sat}	-3			dBm	4
LOS	Optical De-assert	P_d			-34	dBm	4
	Optical Assert	P_a	-45				
LOS hysteresis			1		4	dB	5

Notes:

- 1) The supply current is SFP module's working current.
- 2) For the measurements, the device was driven with 155Mbps data pattern with 2^{23} -1 PRBS payload.
- 3) Optical transition time is the time interval required for the rising or falling edge of an optical pulse to transition between the 20% and 80% amplitudes relative to the logical 1 and 0 levels
- 4) Measured with a PRBS 2^{23} -1 test pattern, @155Mbps, ER=9dB, BER< 10^{-12}
- 5) The LOS Hysteresis minimizes 'chatter' on the output line. In principle, Hysteresis alone does not guarantee chatter-free operation.

Circuit Schematic

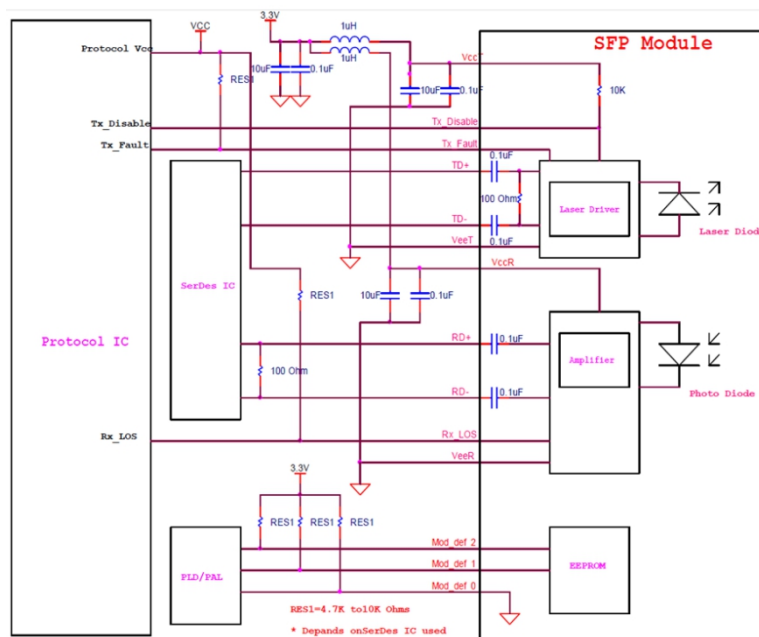

Pin Descriptions

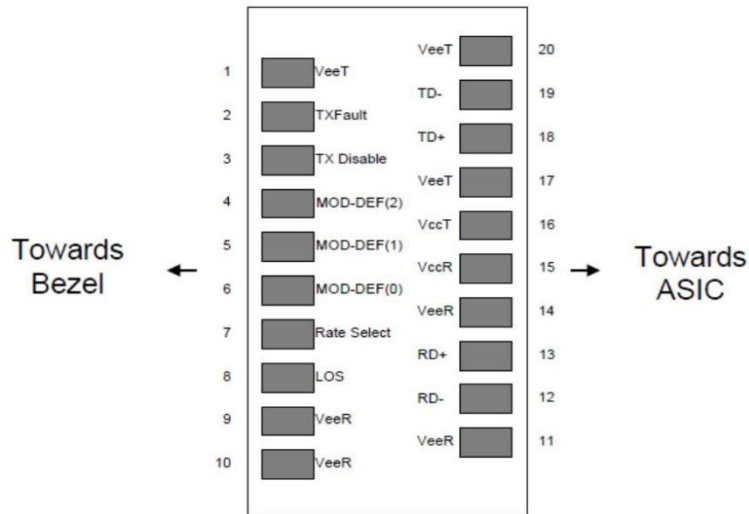

As Viewed Through Top of Board

Pin	Symbol	Function/Description	Ref.
1	VeeT	Transmitter Ground	1
2	TX Fault	Transmitter Fault Indication	3
3	TX Disable	Transmitter Disable-Module disables on high or open	3
4	MOD-DEF2	Module Definition 2-Two wire serial ID interface	3
5	MOD-DEF1	Module Definition 1-Two wire serial ID interface	3
6	MOD-DEF0	Module Definition 0-Two wire serial ID interface	3
7	Rate Select	Not Connected	3
8	LOS	Loss of Signal	3
9	VeeR	Receiver Ground	1
10	VeeR	Receiver Ground	1
11	VeeR	Receiver Ground	1
12	RD-	Inverse Received Data out	3
13	RD+	Received Data out	3
14	VeeR	Receiver Ground	1
15	VccR	Receiver Power — +3.3V±5%	2
16	VccT	Transmitter Power — +3.3 V±5%	2
17	VeeT	Transmitter Ground	1
18	TD+	Transmitter Data In	3
19	TD-	Inverse Transmitter Data In	3
20	VeeT	Transmitter Ground	1

Notes:

- TX Fault is open collector/drain output which should be pulled up externally with a 4.7K – 10KΩ resistor on the host board to supply $V_{ccT}+0.3V$ or $V_{ccR}+0.3V$. When high, this output indicates a laser fault of some kind. Low indicates normal operation. In the low state, the output will be pulled to <math><0.8V</math>.

- 2) TX Disable input is used to shut down the laser output per the state table below. It is pulled up within the module with a 4.7K – 10K Resistor.
 Low (0 – 0.8V): Transmitter on;
 Between (0.8V and 2V): Undefined High;
 (2.0 – VccT): Transmitter Disabled;
 Open: Transmitter Disabled.
- 3) Mod-Def 0, 1, 2. These are the module definition pins. They should be pulled up with a 4.7 – 10K Resistor on the host board to supply less than VccT+0.3V or VccR+0.3V.
 Mod-Def 0 is grounded by the module to indicate that the module is present.
 Mod-Def 1 is clock line of two wire serial interface for optional serial ID.
 Mod-Def 2 is data line of two wire serial interface for optional serial ID.
- 4) LOS (Loss of signal) is an open collector/drain output which should be pulled up externally with a 4.7 – 10K resistor on the host board to supply <math><V_{ccT}+0.3V</math> or <math><V_{ccR}+0.3V</math>. When high, this output indicates the received optical power is below the worst case receiver sensitivity (as defined by the standard in use). Low indicates normal operation. In the low state, the output will be pulled to <math><0.8V</math>.
- 5) RD-/+ : These are the differential receiver outputs. They are AC coupled 100Ω differential lines which should be terminated with 100Ω differential at the user SERDES. The AC coupling is done inside the module and thus not required on the host board.
- 6) VccR and VccT are the receiver and transmitter power supplies. They are defined as 3.3V±5% at the SFP connector pin. The in-rush current will typically be no more than 30mA above steady state supply current after 500ns.
- 7) TD-/+ : These are the differential transmitter inputs. They are AC coupled differential lines with 100Ω differential termination inside the module. The AC coupling is done inside the module and is thus not required on host board.

Package Outline

Dimensions are in millimeters. All dimensions are ±0.2mm unless otherwise specified.(Unit: mm)

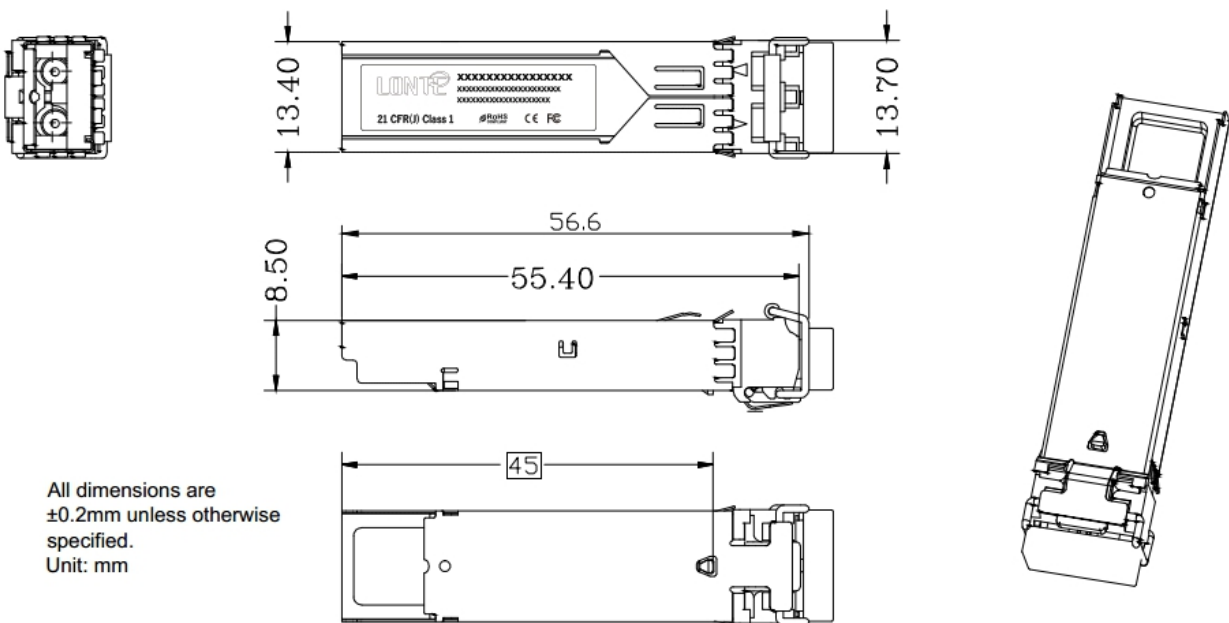

Regulatory Compliance

Feature	Test	Method
Electrostatic Discharge (ESD) to the Electrical Pins	MIL-STD-883E Method 3015.7	Class 1(>1000V for SFI pins, >2000V for other pins.)
Electrostatic Discharge (ESD) Immunity	IEC61000-4-2	Class 2(>4.0kV)
Electromagnetic Interference (EMI)	CISPR22 ITE Class B FCC Class B CENELEC EN55022 VCCI Class 1	Comply with standard
Immunity	IEC61000-4-3	Comply with standard
Eye Safety	FDA 21CFR 1040.10 and 1040.11 EN (IEC) 60825-1,2	Compatible with Class I laser Product

Ordering information

Part. No	Specifications								
	Pack	Rate	Tx (nm)	Po (dBm)	RX	Sen (dBm)	Temp (°C)	Reach (km)	DDM
BSFP-MM13102K	SFP	155M	1310	-15~-8	PIN	<-24	0~70	2	Y
BSFP-MM13102KH	SFP	155M	1310	-15~-8	PIN	<-24	-40~85	2	Y